

GEMINI-MLX850 INSTALLATION INSTRUCTIONS

Tools needed: 2mm hex key, Philips screwdriver (not provided)

IMPORTANT: The telescope needs to be roughly in focus (on a star) prior to installing the Gemini-MLX850 bracket. By necessity, the Gemini will connect to the fine focus pinion shaft instead of the coarse focus pinion shaft. This means that there is less available EAF travel, so starting with the telescope in rough focus ensures that there is plenty of focus travel after installation.

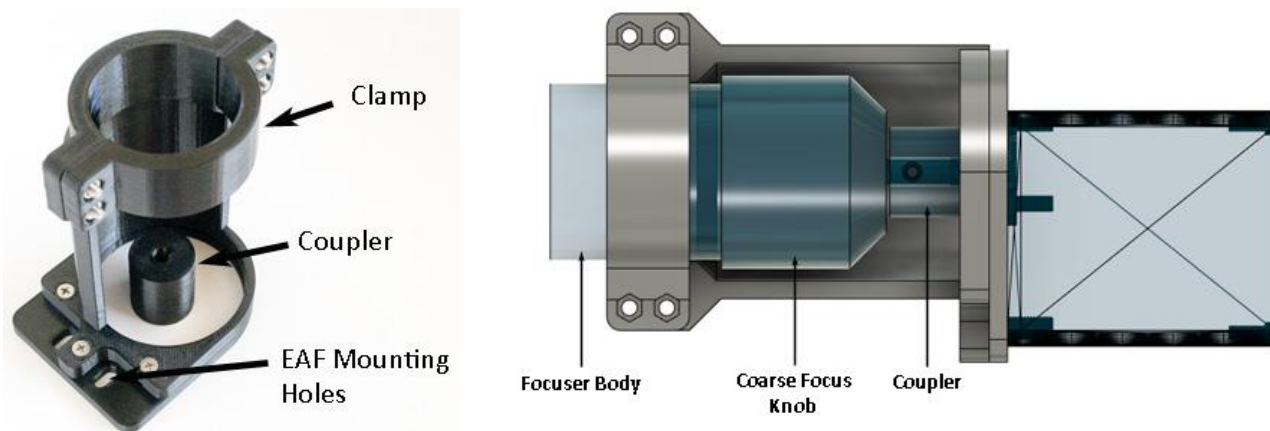

Warning: Do not attempt to remove the coarse focus knob. Meade used a thread locker on the screws and any attempt to remove the coarse knob screws could damage the screw heads.

STEP 1

- Remove the fine focus knob from the focuser pinion shaft.

STEP 2

- Separate the two halves of the clamp.
- Place the clamp around the focuser body and temporarily secure the bracket to the focuser body. Adjust the lateral position of the bracket so that the coarse focus knob is very near to the clamp end of the bracket, but still rotates freely without contacting the side of the bracket.

STEP 3

- Slide the coupler onto the Gemini pinion shaft. There is a flat on the coupler hole that matches the flat on the Gemini pinion shaft.
- Secure the coupler to the Gemini pinion shaft by tightening the two set screws with a 2mm hex key until the set screw contacts the Gemini pinion shaft and then tighten 1/8 turn farther. Do not over-tighten the set screws.
- Slide the other end of the coupler onto the focuser pinion shaft and secure the Gemini to the bracket with the Gemini supplied M4 screws.

STEP 4

- Adjust the lateral position of the bracket so that the coupler set screws have full contact with the focuser pinion shaft. Fully tighten the clamp screws to secure the bracket to the focuser body.
- Tighten the set screws on the coupler to the focuser pinion shaft. Do not over-tighten the set screws.